

LTS CF SERIES COMPACT VALVES

LTS CF Series Compact Valve System

LTS offers a comprehensive range of Compact Trunnion Mounted Ball, Check and Gate valves based around our high performance, Metal to Metal Sealing FlangeTec® Compact Flange design. Dramatic space and weight savings are achieved over standard ASME B16.34, API 6D and API 6A equivalent valves. External load capabilities are built in to the flange design making them ideal for HP/HT and extreme service applications. Full design compliance meeting both Valve, and piping Codes are performed as well as in-house Linear, Non Linear and Thermal FEA analysis. Valve bore options include Full Port, Reduced Port and Exact Port making them ideal for Pigging Systems and Subsea Tie Backs.

LTS CF Series Valve Products

- Trunnion Mounted Ball Valve (Metal & Soft Seated)
- Gate Valve (Slab and Expanding Gate)
- Check Valve (Metal Seated)
- Choke and Flow Control (Cage & Needle/Seat Trims)

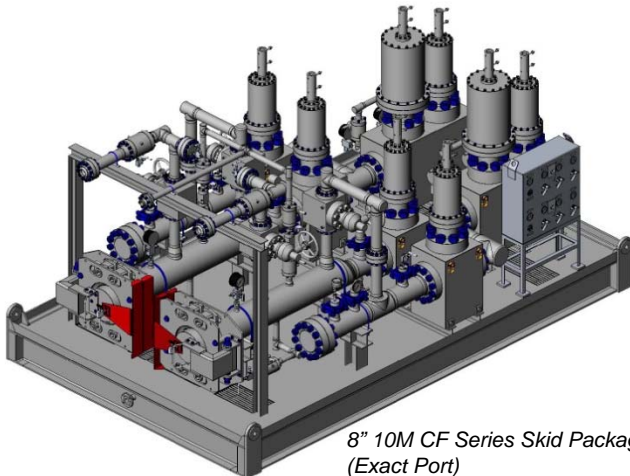

8" 10M CF Series Skid Package
(Exact Port)

Skid Integration

LTS offers complete design and supply of Skid Packages for HP/HT Pig Launchers and Receivers, Manifolds and Flowlines Systems utilizing our CF Series Valves as well as standard ASME/API Flanges and Clamp Connectors.



8" 15M CF Series Gate Valve (Exact Port) - LTS Pigging System

Specifications

Pressure:	ASME 1500lbs thru 4500lbs API Class 5M thru 20M Custom
Temperature:	-150°F/+500°F (-101°C/+260°C)
Sizes:	1" to 36" (25mm to 900mm)
Materials:	Carbon, Alloy, Stainless Steel, Duplex, S. Duplex, Nickel Alloys
Codes:	API 6A, API 6D, ASME B16.34, ASME VIII Div. 2, Norsok

Applications

- High Pressure Pigging Systems
- High Pressure Manifold Systems
- High Pressure Flowlines
- High Pressure Cyclones
- High Pressure Chemical Injection
- High Pressure Gas and Water Injection

Flow Control

Production Chokes and In-Line Flow Control Valves are offered with FlangeTec CF Series Flanges for HP Manifold, Gas Lift and Waterflood applications meeting NACE MR-0175

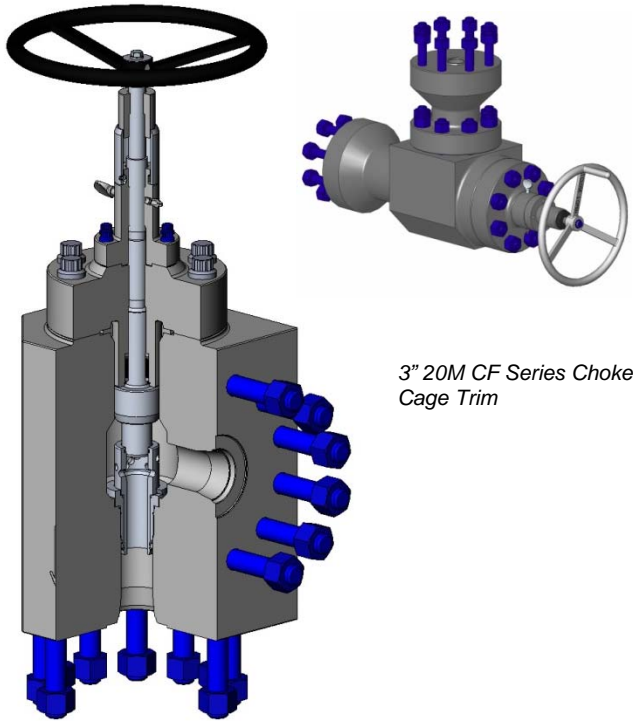

3" 20M CF Series Choke Cage Trim



4" 15M CF Series Gate Valve (Full Port) – LTS Pigging System

LTS CF Series HP/HT Design

LTS in-house design capabilities feature the latest SolidWorks 3D modeling software which allows quick and simple transition from design to manufacturing. For more demanding applications where combinations of pressure, temperature and cyclic conditions exist, FEA analysis can be carried out to substantiate both design and external load capabilities.

6" 15M CF Series Gate Valve (Full Port) – Metal Seated

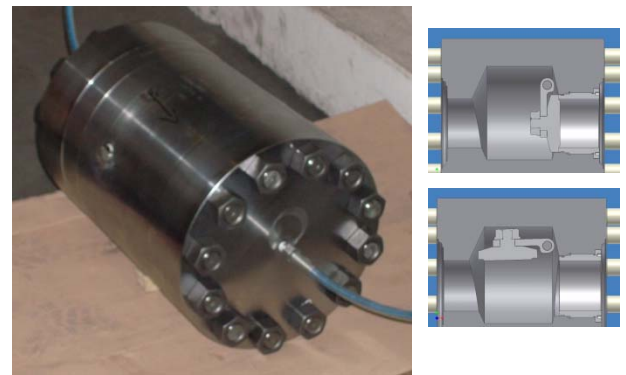

4" 15M CF Series Check Valve (Metal Seated)
Gas Testing per API 6A PSL-3G

Need More Information?

For further information on LTS Products and Services please visit our website at www.ltsenergy.com or call our Sales Team